

Important safety instructions

The DX-TVM102 TV mount is designed to support a Flat Panel TV weighing up to 50 lbs. (22.7 kg).

Caution

The DX-TVM102 is designed for use in wood frame walls only! The weight of your TV must not exceed 50 lbs. (22.7 kg). The wall must be capable of supporting five times the weight of the TV and wall mount combined.

Do not use this product for any purpose not explicitly specified by Dynex. Improper installation may cause property damage or personal injury. If you do not understand these directions, or have doubts about the safety of the installation, contact Customer Service or call a qualified contractor. Dynex is not responsible for damage or injury caused by incorrect installation or use.

Warning

This product contains small items that could be a choking hazard if swallowed. Keep these items away from young children.

Supplied parts and hardware

Before starting assembly, verify all parts are included and undamaged. If any parts are missing or damaged, do not return the item to your dealer, but contact Customer Service. Never use damaged parts.

PARTS LIST

Note: Not all parts will be used

Missing parts? Call 800-573-2860

- A Wall bracket (1)
- B Left TV bracket (1)
- C Right TV bracket (1)
- D M4 × 0.47" (12 mm) screws (4)
- E M5 × 0.47" (12 mm) screws (4)
- F M6 × 0.47" (12 mm) screws (4)
- G M6 × 0.79" (20 mm) screws (4)
- H M4 × 1.18" (30 mm) screws (4)
- I M5 × 1.18" (30 mm) screws (4)
- J M6 × 1.38" (35 mm) screws (4)
- K M4/M5 washer (8)
- L M6 washer (4)
- M M4/M5 spacer (4)
- N M6 spacer (4)
- O 5/16" (7.9 mm) washer (2)
- P Tilt bracket (2)
- Q 5/16" × 2.5" (63.5 mm) lag bolt (2)
- R Carriage bolt (4)
- S Nylock nut (4)

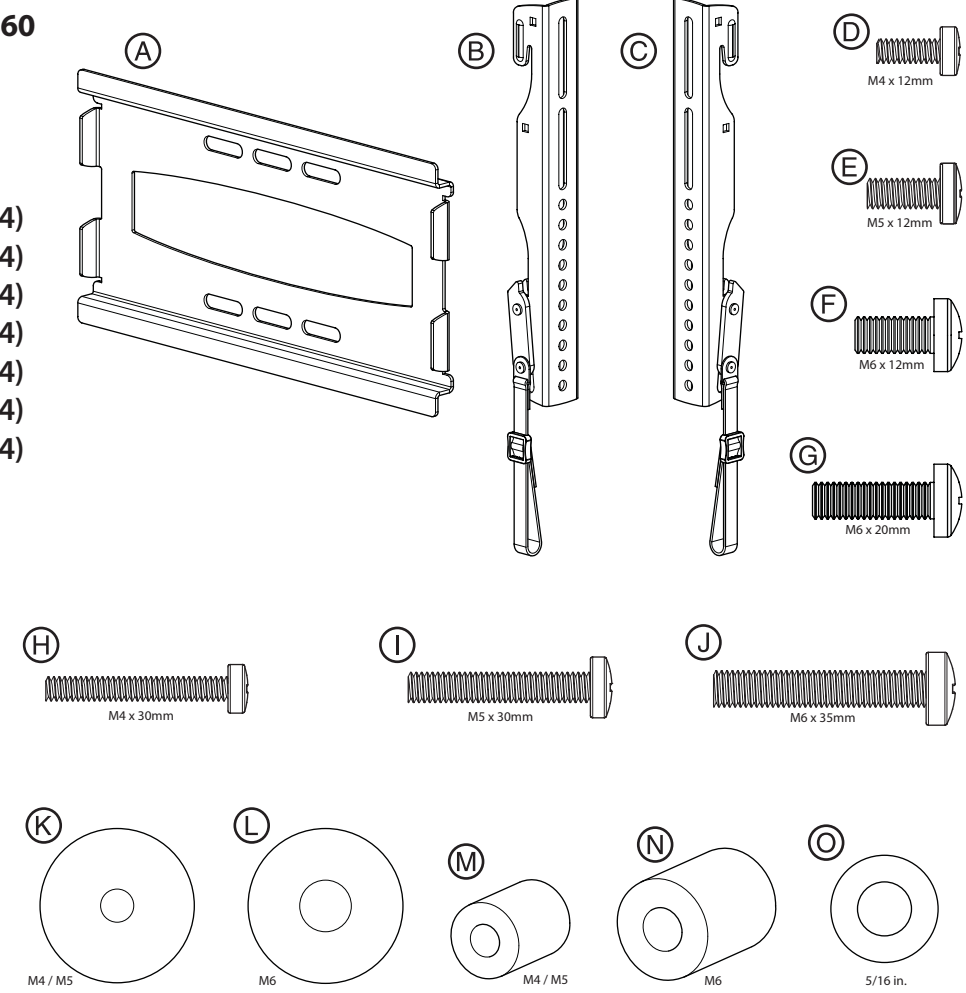

Tools you will need:

- Power drill
- 3/16" wood drill bit
- Phillips screwdriver
- Level
- Socket wrench with 1/2 in. socket
- Pencil
- Stud finder
- Adjustable wrench
- Awl

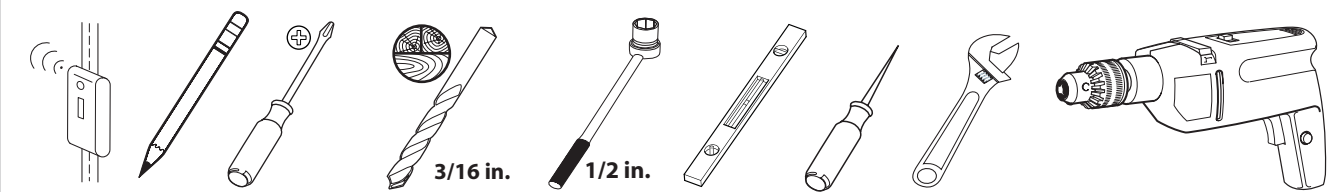
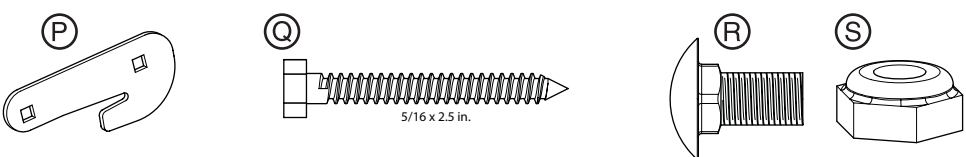

1 Attach the wall bracket to the wall studs.

Caution: Avoid potential injuries or property damage! Any material covering the wall must not exceed 16 mm (5/8 in.).

Caution: Avoid potential injury or property damage! Do not overtighten the lag bolts [Q]. Tighten the lag bolts [Q] only until the washers [O] are pulled firmly against the wall bracket [A].

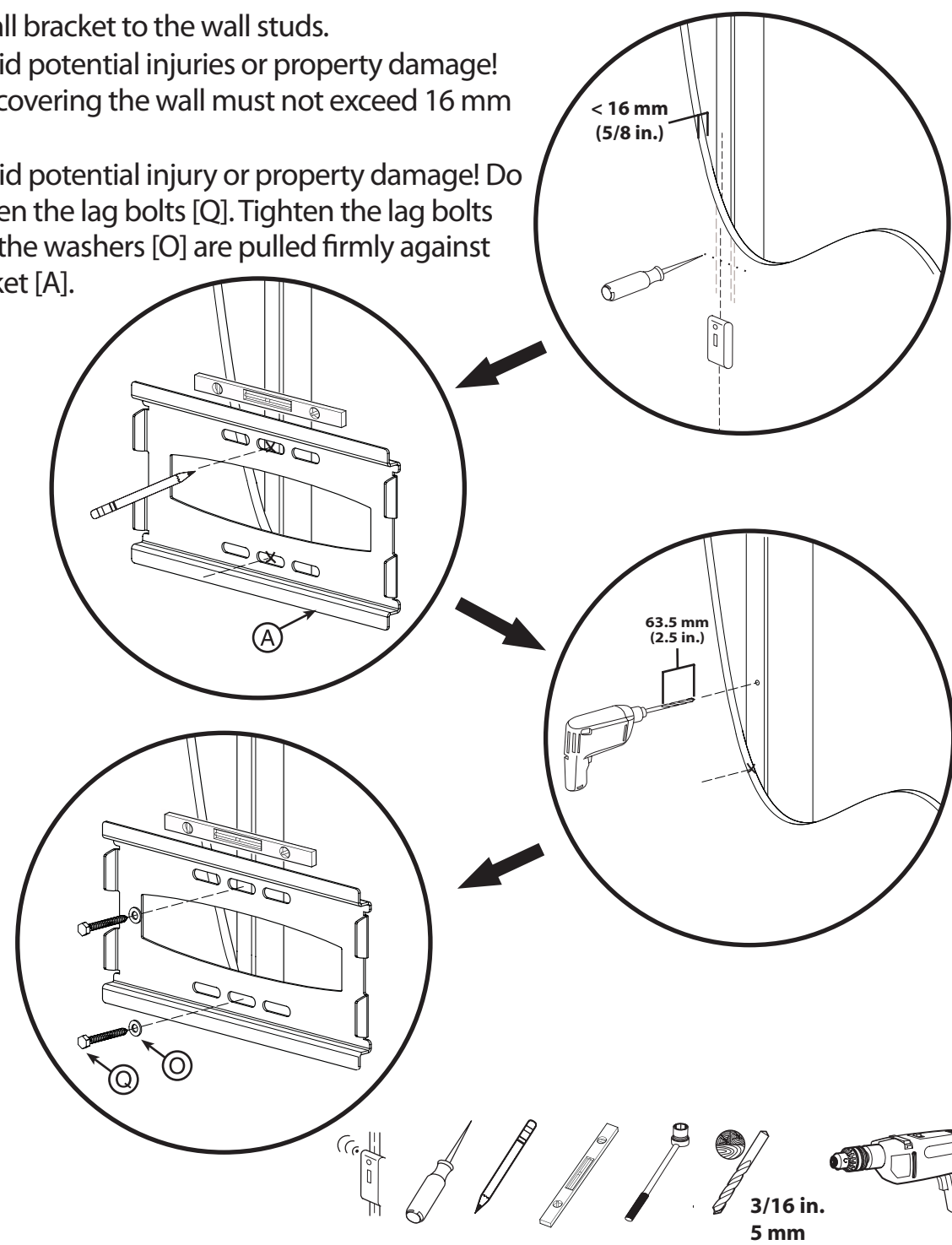

2 Attach the TV bracket

Step 2a: TVs with flat back panels.

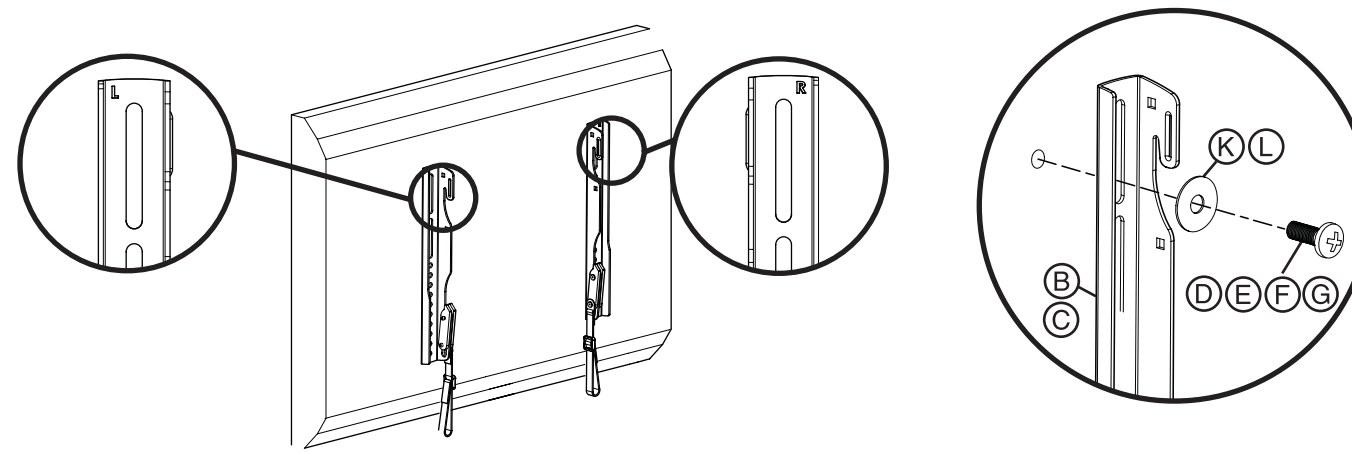

Step 2b: TVs with rounded or angular back panels.

Optional: Use washer [K] with M4 or M5 hardware only.

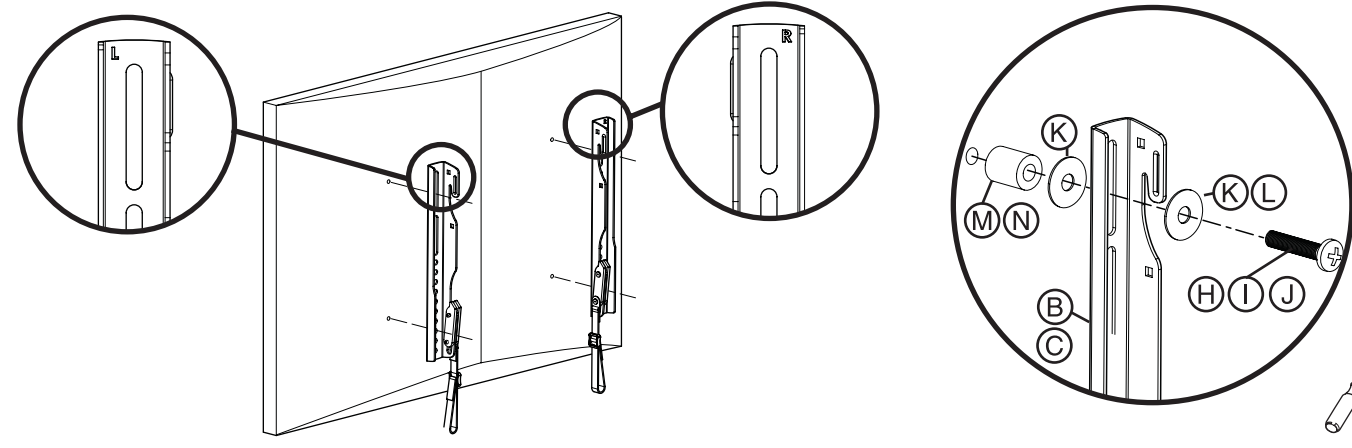

3 Adjust the release straps length

Adjust the release straps so they are level with bottom of the TV; this allows the straps to be accessible, yet concealed, when the TV is on the wall.

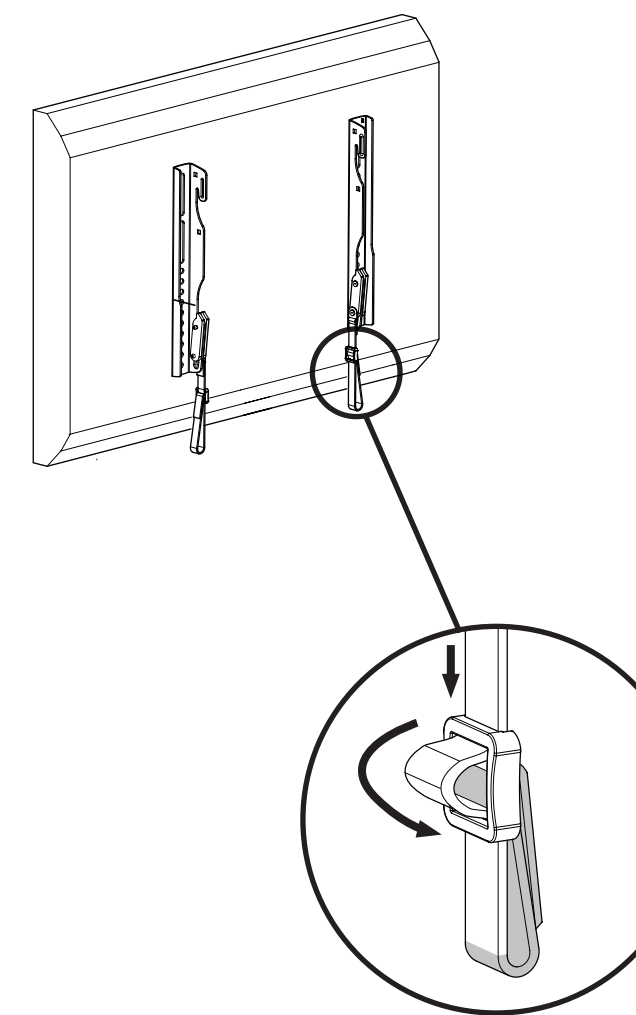

4 Set the viewing angle (optional)

Attach the tilt brackets.

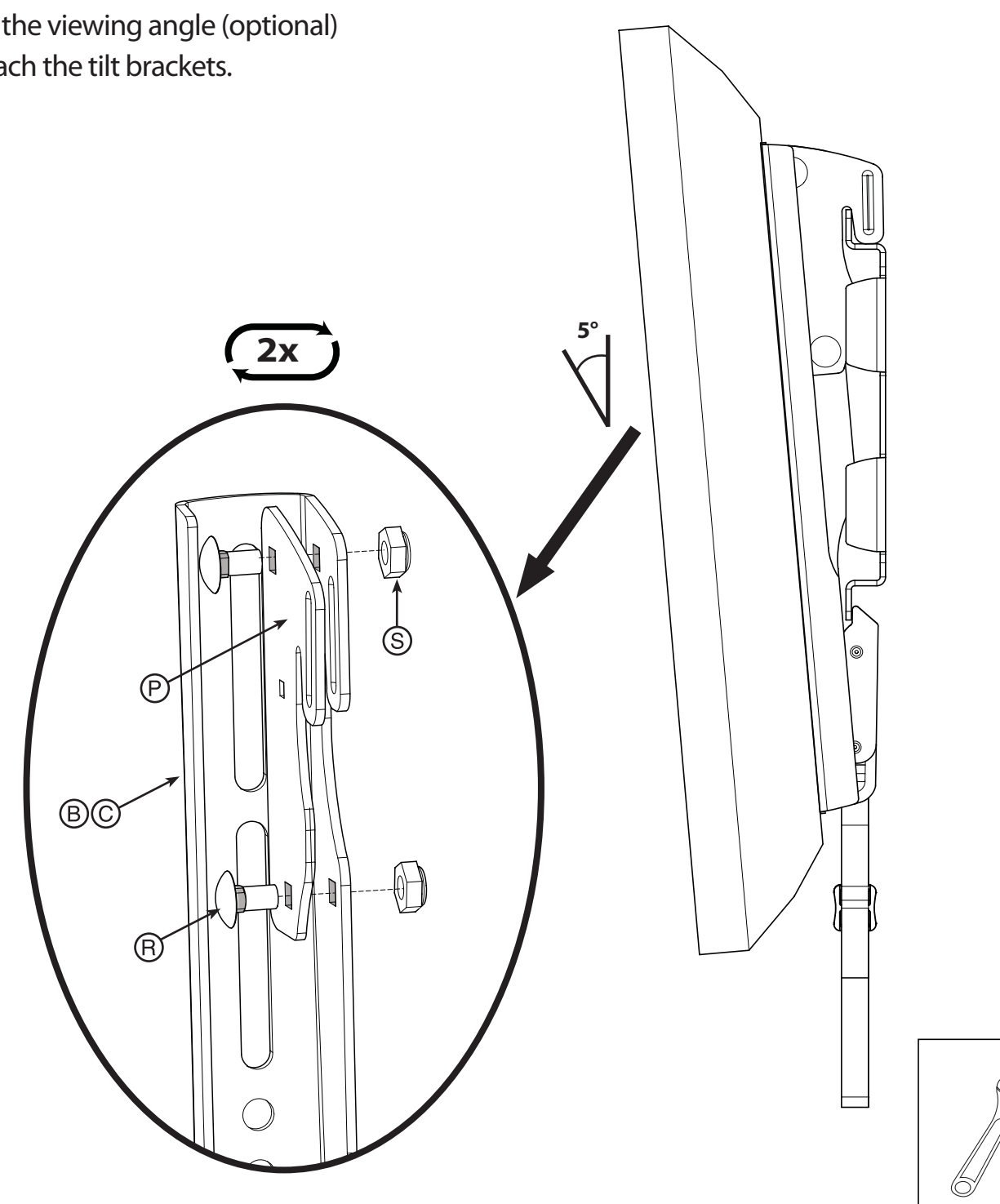

5 Mount the TV to the wall bracket

First mount the top hooks of the TV brackets onto the wall bracket, then press the bottom of the TV brackets against the wall bracket until they snap into place.



HEAVY! You will need assistance with this step.

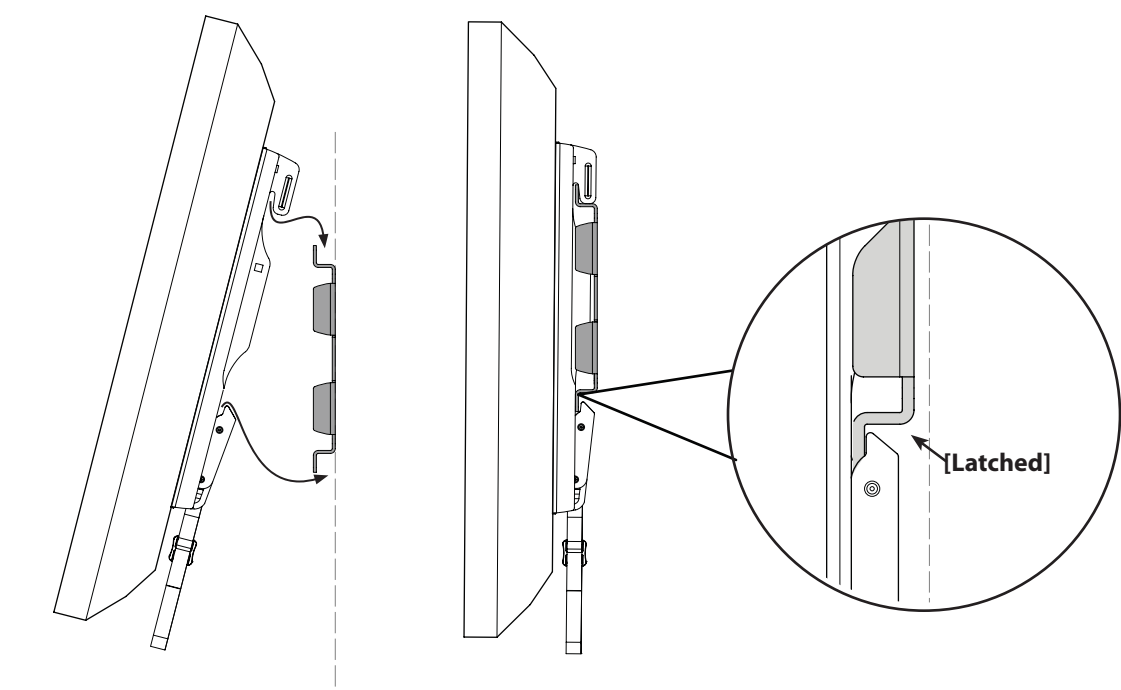

Maintenance

To remove the TV from the wall bracket, pull down on the release straps, pull the bottom of the TV away from the wall bracket, then lift the TV completely off the wall bracket.

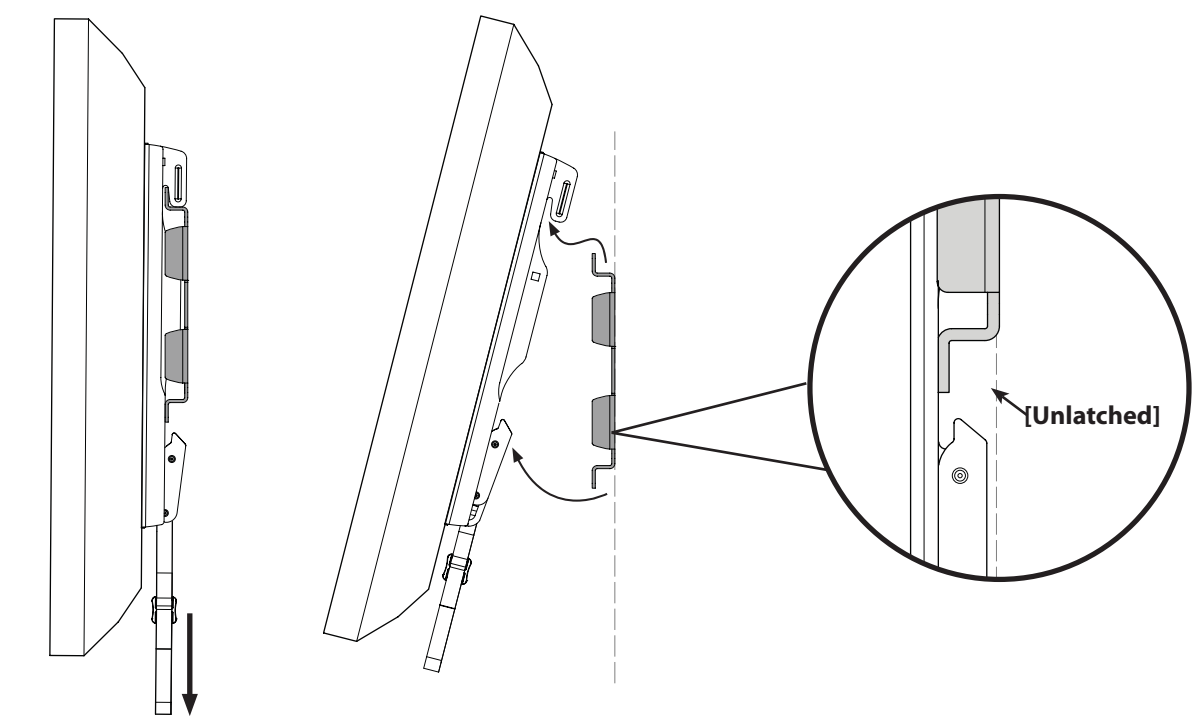

DYNEX™

DX-TVM102 Slim-Profile TV Mount

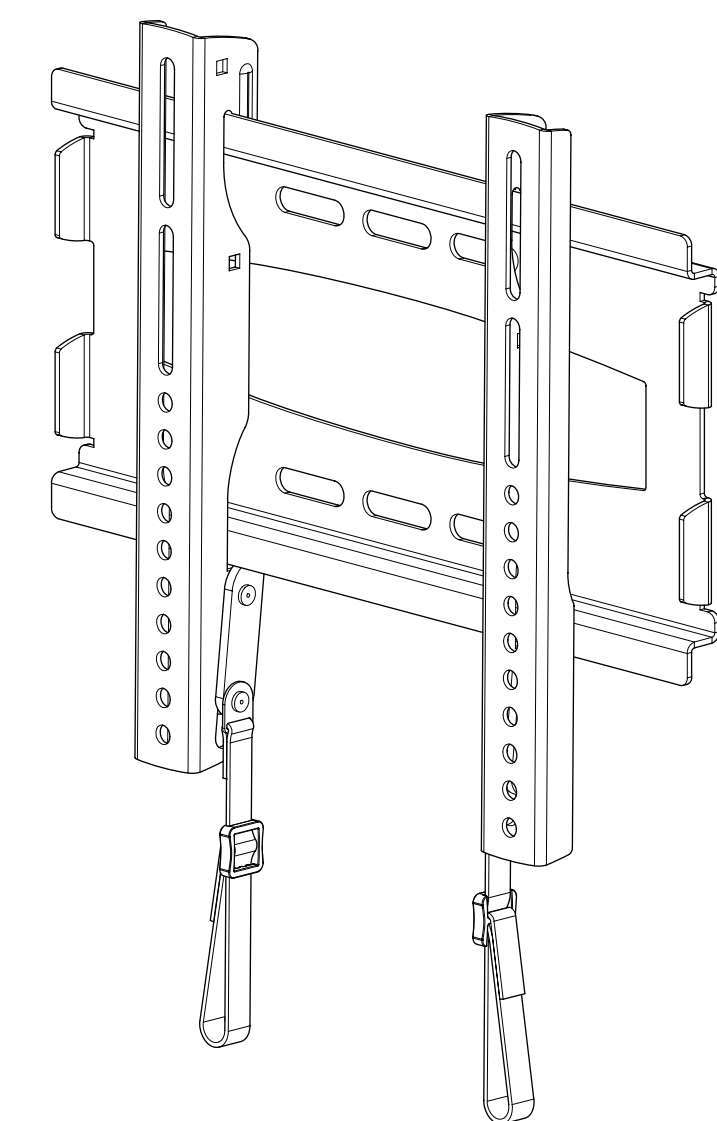

USER GUIDE